

تشبيد المباني ذات الارتفاع المنخفض على التربة القابلة للإنتفاخ *

THE CONSTRUCTION OF LOW - RISE BUILDINGS ON EXPANSIVE CLAY

د/محمد مصطفى الشريف

كلية الهندسة جامعة قناة السويس

الكلية التقنية بأبها السعودية حاليا

تتغير أحجام التربة بتغير المحتوى المائي لها وتتوقف قيمة هذا التغير في الحجم على كثيرا من خواص التربة ونظرا لتأثير هذا التغير في حجم التربة على أساسات المباني وحيث انه توجد صعوبة في التحكم في هذا التغير لذا يجب معالجة ذلك عن طريق الاهتمام بالأساسات نفسها لتجنب مخاطر إنتفاخ التربة تحتها

والغرض الرئيسي من هذا البحث دراسة مدى تأثير تغير حجم التربة القابلة للإنتفاخ على أساسات المباني والتي تتأثر كثيرا بتغير المحتوى المائي للتربة كذلك دراسة مدى تأثير جذور النباتات بأنواعها المختلفة على تغير حجم التربة والتي تؤثر بالتالى على أساسات المباني التى تكون قريبة من جذور النباتات بالإضافة إلى ذلك يتعرض البحث بالشرح للإحتياجات الواجب إتباعها وأخذها فى الإعتبار أثناء تصميم الأساسات وتنفيذ المنشآت على التربة القابلة للإنتفاخ وقد توصل البحث إلى كثيرا من التوصيات والنتائج التى تحدد أقل مسافة مسموح بها بين الأشجار والأساسات التى تتوقف على نوع النباتات وطول الجذور والتى تتوثر إلى حد كبير على إنتفاخ التربة وقد تعرض البحث إلى التقارير والمواصفات الهندسية للمباني والمحددة بواسطة نقابة المهندسين البريطانية

ويحتوى البحث على جداول قد تم وضعها لتحديد أنواع الأساسات المختلفة وعمق التأسيس مع بعد النباتات المختلفة وكذلك درجة إنتفاخ التربة وكذلك تعرض البحث لتوصيات كيفية تقليل تأثير إنتفاخ التربة على الأساسات وكذلك تم تصنيف درجة إنتفاخ التربة إلى ثلاث درجات طبقا لقيم معامل اللدونة بحيث يستطيع المصمم الأساسات أخذ ذلك فى الإعتبار

وفى نهاية البحث تم وضع توصيات للإحتياجات فى تنفيذ الأنواع المختلفة للأساسات على التربة القابلة للإنتفاخ

THE CONSTRUCTION OF LOW-RISE BUILDINGS ON EXPANSIVE CLAY

Mohamed EL-Sherif, BSc, MSc, PhD,
Abha College of Technology, Department of Construction, K.S.A.

Ibrahim Abdul Rashid, BSc, MSc, PhD,
Zagaziq University, Faculty of Engineering, Egypt

Mahmoud Eltoukhy, BSc, MSc, CEng, MIStructE,
Abha College of Technology, Department of Construction, K.S.A.

Synopsis

Most clay soils change volume as their moisture content changes. The amount of volume change depends on the amount of clay and its characteristics in the soil. Little can be done to improve the swelling and shrinkage characteristics of the soil and consequently there is a need for stronger and deeper foundations and more relatively expensive techniques. The purpose of this paper is to review the phenomena of expansive soils resulted from the existence of trees and the current status on legal aspects of expansive soil. This paper also explains the structural precautions which should be implemented when considering the design and constructional details of foundations built on expansive soil.

1 Introduction

Volume change related to the percentage of the water content variations are the characteristic of clay and the majority of mud rocks with clay minerals playing the significant part in the behavior. Because of their specific surface area, these minerals are always hydrated in nature with absorbed water. The properties of clay are dependent on the thickness of this hydration shell which will vary according to the clay mineral group. The basic building block of clay mineral are Silicon-Oxygen Tetrahedra, Aluminum-Oxygen Octahedra and Magnesium-Oxygen Octahedra; *Taylor, (1985)*. These substances promote ground movements by virtue of volumetric changes arising from physicochemical reactions. In addition to clay mineral hydration, it is the instability of chemically, biochemically precipitated soluble minerals in present weathering environments which promotes deformation problems in the near surface zone. These deformations depend on the mineral species, the salt concentration of the pore water, the valence of the exchangeable cation, the degree of consolidation and bonding by Carbonates, Oxides and organic matters. In order to use a more practical guide to assess the expansive potential is to relate it to clay soil Atterberg limits as they have been widely used to identify expansive soils as shown in figure (1). It is worth mentioning that Arabian Gulf and parts of North Africa are cited as modern depositional environments where clay minerals expansion have caused construction damages to man made structures, particularly low-rise buildings.

Figure 1
Atterberg Limits used to Identify Expansive Soils

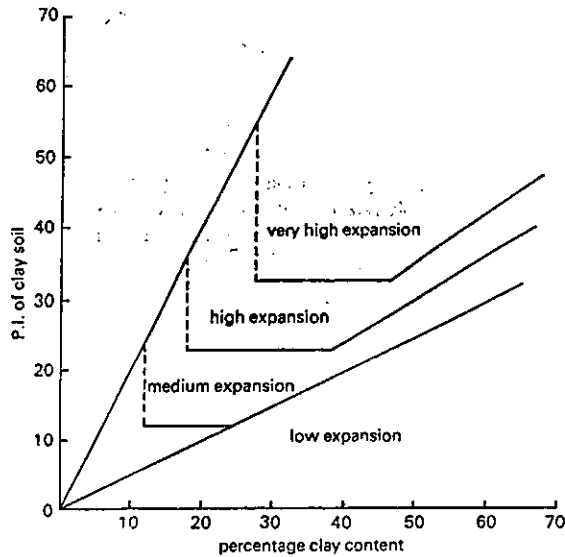

2 Volume Change of Soils

Clay soils undergo a volume change when the moisture content is changed. Decreasing the water content will cause shrinkage and increasing the water content results in swelling. The swelling of clays results from the increase in the thickness of the diffuse ion layer as water content increases. Monovalent exchangeable sodium ions causes greater swelling than divalent calcium ions, *Das (1983)*. Figure (2) shows the axial shrinkage of silty clay soil. The shrinkage in this case was measured after compacting samples at various moisture contents. Figure (3) shows the swelling pressure developed in a compacted sandy clay when samples were confined to constant volume by means of compaction molds and pistons on their upper surfaces and free access of water was given to all samples; *Redrawn, (1959)*.

Figure 2
The Axial Shrinkage of Silty Clay Soils

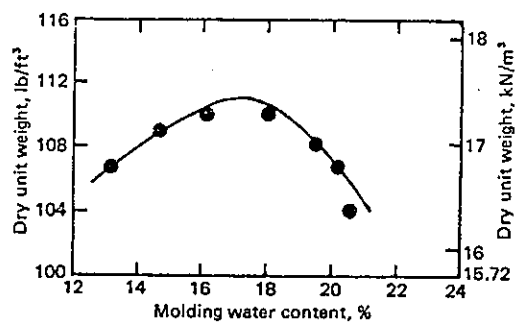
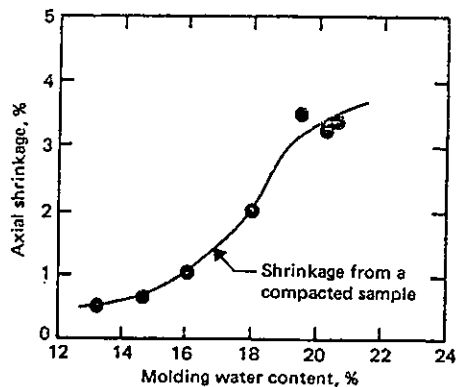
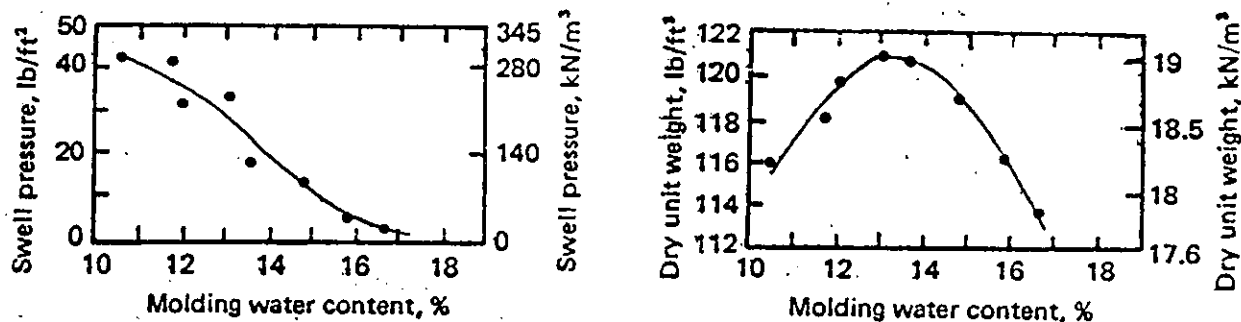

Figure 3
The Swelling Pressure Developed in a Compacted Sandy Clay Sample



3 Swelling Potential of clay

As a result of the potential danger to foundations built on expansive soils, there is a necessity to identify these soils. A number of investigators carried out a few attempts to establish a reliable method for soil identification purposes; *Holtz and Gibbs, (1956)*; *Seed et al, (1962)*; *Nayak and Christensen, (1971)*. *Seed and al, (1962)* conducted several tests on laboratory compacted sand-clay mineral mixtures to determine their swell potential. Swell potential is defined as the percentage of swell under a 6.9KN/m² surcharge of a laterally confined specimen compacted at optimum moisture content to maximum dry density in the standard AASHTO compaction test. A relationship was established between the swell potential, the activity and the percent of clay fraction the soil:

$$S = (3.6 \times 10^{-5}) A^{2.44} C^{3.44} \quad (1)$$

where S= swell potential (percent of axial swell under 6.9KN/m² pressure)

C= percent of clay fraction, by weight

A= activity = $\frac{\Delta(PI)}{\Delta C}$

Equation (1) was further modified to include the plasticity index of the soil:

$$S = K (60) (PI)^{2.44} \quad (2)$$

where $K = 3.6 \times 10^{-5}$

$$S = (2.16 \times 10^{-3}) (PI)^{2.44}$$

Seed et al, (1962) made the following classification which conform to the USBR classification:

Degree of expansion	S
Low	0-1.5
Medium	1.5-5
High	5-25
Very High	+25

4 The Effect of Vegetation

Knowledge of the structural movement that can be caused by loss of water through the growth of vegetation and regaining this water by removing the vegetation seem to have been overlooked. Structural problems associated with vegetation and climate were of long standing. Tree roots can extract large quantities of water from soil, for example a fully grown poplar uses over 50 000 liters in a year. When a clay soil exists, this will lead to a drying shrinkage. The shrinkage magnitude depends on:

the properties of clay,
the nature of the tree, and
the moisture requirements.
the nature of the applied Loads

If tree roots consume moisture from under, or near to, foundations, the foundation will suffer from subsidence. This subsidence is likely to be uneven. Unfortunately, the adverse effect of foundations subsidence as a result of drying actions of tree roots in areas of shrinkable clays is not fully appreciated by many involved in the design and construction process.

It also important to realize that, when trees are felled, clay soils will gradually swell as water returns to the soil. Therefore, a clay construction site cleared of trees should be allowed to recover before the construction process begins. If this is not possible for economic or any other reasons, in this case the foundations need to be specially designed in order to avoid the structural damages caused by ground movement.

4.1 *Effects of Foundation Movement*

The critical structural foundation subsidence took place when expansive clays have dried excessively through the reduction of the moisture contents within the soil as a result of growing vegetation. Such drying is likely to be near the corner of foundations; *Ransom, (1987)*. As the soil moves away from underneath the foundations, the structure pushes down and part of the foundations become suspended and deflect over the run-away soil. This leads to cracking the structural walls in this local areas. The cracks are predominately diagonal and are widest at the top corners of the structure and decreases as the approach ground level. Clay soils which display the largest movement during drying are the firm shrinkable clay. It becomes necessary to develop a recognized formal method of assessing the structural damages resulted from the foundation movements. Tomlinson et al, (1978) produced an objective method of assessment which utilizes the visible damage classification to walls classification shown in table (1).

When using table (1), it must be stressed that crack width is only one factor in assessing the scale of damage and should not be taken into consideration on its own when assessing the degree of damage. The function of the structure as well as the location of the cracks in the Structure should also be taken into consideration when assessing the Category Damage.

Table 1 Classification of visible damage to walls (BRE, 1981)

<i>Category of Damage</i>	<i>Degree of Damage</i>	<i>Description of typical damage</i>	<i>Approximate Crack Width mm</i>
0	Negligible	Hairlines cracks of less than 0.1mm	Up 0.1 mm ²
1	Very Slight	Fine cracks which can easily be Up to 1 mm ² treated during normal decoration. Isolated slight fracturing in building. Cracks rarely visible in external bricks	Up to 1 mm ²
2	Slight	Cracks easily filled. Recurrent cracks can be masked by suitable linings. Cracks not necessarily visible externally. Some external repointing may be necessary to ensure watertightness. Doors & windows may stick slightly.	Up to 5 mm ²
3	Moderate	The cracks require some openings up & can be patched by a mason. Repointing of external brick-work & possibly a small amount of bricks to be replaced. Doors & windows sticking. Service pipes may be fractured. Water tightness may be impaired.	5 mm ² to 15 mm ² Number of cracks up to 3
4	Severe	Extensive repair work involving breaking out & replacing sections of walls specially over doors & windows, windows & door frames distorted, floor slopping noticeably, walls leaning or bulging, some loss of bearing in beams, Service pipes disrupted.	15 mm ² to 25 mm ² depends on number of crack
5	Very Severe	This require a major repair work involving partial or complete rebuilding. Beams lose bearing, walls lean badly and require shoring. Windows broken with distortion, danger of instability.	Usualu grater than 25mm ² but depends on number of cracks

Source: Building Research Establishment, (1981) **Assessment of Damage in Low-Rise Buildings**. BRE Digest 251, HMSO, London.

4.2 *The Current Status on Legal Aspects*

The scale of damage to low-rise structures as a result of ground movements due to the phenomena of expansive clay can be seen with reference to the latest and current claims in the U.S.A. It has been estimated that the foundations subsidence due to ground movements cost an annual repair bill of \$8 billion U.S. Dollars; *Earl Jones, (1979)*.

In the United Kingdom, legal claims were made against 15 major insurance companies rose from 164 claims in 1971 to 20922 claims in 1976, falling to 7454 in 1979. *Reece, (1980)* estimated the total cost of claim related to subsidence mounted to 250 million pounds during the period between 1971 to 1980.

Problems arising from expansive soil are the most frequent area of litigation. Insurance company usually do not question disasters such as earthquakes, floods or tornadoes and engineers do rarely get sued as a result of any of the above disasters. Engineers are usually accused of professional negligence when a structure is damage as a result of ground movements due to expansive clay as it is assumed that a prudent practicing with a state of art should be able to design and construct a risk-free structure on expansive clay.

In the court of law, expert witnesses summoned by both the plaintiff and the defendant can have totally opposite views and the attorneys will continue to find loopholes in the exhibited documents by both sides. judges and juries are confused and the truth of the matter may never be discovered. The future trends can see little relief in the legal system towards the litigation of swelling clay; *Chen, (1987)*.

4.3 *The Structural Design of Foundations on Expansive Soil*

Heave of expansive soils is difficult to predict and therefore special precautions should be taken into consideration when looking at building near trees. When the water content in expansive clays increases, its volume increases and the result is movements in both the vertical and horizontal directions. The process of decreasing the water content is termed *desiccation*. The process of regaining this water in soils is termed *Heave*.

Therefore, it is important to study any local recorded information as well as carrying out adequate site reconnaissance in order to determine the topography, the type of ground, the vegetation presence and the ground water. It is also important to record heights and types of trees and hedgerows on and adjacent to the site. It should be noticed that failure to take these essentially simple steps may lead to incurring unnecessary much expenditure due to soil and consequently foundation movements.

It is necessary to take the foundations down to a depth which should eliminate significant ground movements. The relationship between the tree height and the distance between the tree and the foundations is well documented in the *National House Building Council (NHBC)* clause (3), (1974) and is shown in table (2).

Table 2
The Minimum Distance Between Trees and Structures
(Clause 3 of NHBC Practice, 1974)

Choose the Right Kind of Foundation for Clay Soils

On shrinkable clay soil, special foundations are needed for a building near a tree than two thirds of its mature height in the case of Poplars, Elms and Willows.

The right kind of foundation can be:

Pile and beam

Raft

Deep strip

Shallow strip foundations must not be used near trees

"D" is the distance between tree & foundations, "H" is the tree height.

Species of tree Distance from the dwelling as a proportion of tree height D/H

	$1/6$	$1/4$	$1/3$	$1/2$	$2/3$	$3/4$	1
	<i>Depth of Trench (M)</i>						
<i>Polar, Elm & Willow</i>	---	2.8	2.6	2.3	2.1	1.9	1.5
<i>All Others</i>	---	2.4	2.1	1.5	1.5	1.2	1.0

When Trees are in rows or groups, up to 50% extra depth are required.

Table (2) NHBC was rewritten in 1985 with a new title "Building near trees, and a research was carried out in the area of expansive soil to enable the foundation depths to be related to the plasticity of clay and the different types of trees. Building near trees, NHBC, (1985) classified the soil into three categories: high, medium and low shrinkage potential and tied these categories with the plasticity index in table (3).

Table 3

<i>Plasticity Index</i>	<i>Shrinkage Potential</i>
<i>Greater than 40%</i>	<i>High</i>
<i>20% to 40%</i>	<i>Medium</i>
<i>10% to 20%</i>	<i>Low</i>

The NHBC, (1985) practice note 3 classified the trees into High, moderate and low water demand as well as their potential heights on clay soils, and the foundation depth will limit the foundations movement related to expansive clay and not necessarily eliminating them. The required foundation depths can be derived from table and Figure (4). When sites are not affected by trees, the foundation depths can be taken from table (5).

Table 4

Foundation Depth Tables

Source: Atkins, R, The Structural Engineers/Volume 72/No. 16/16 August (1994)
 High Shrinkage Soil Plasticity Index greater than 40%

High water demand BROAD LEAF Trees including

Elm		Oak		Poplar		Willow	
English	24	English	20	Hybrid	28	Crack	24
Wheatley	22	Holm	16	Lombardy	25	Weeping	16
Wych	18	Red	24			White	24
Eucalyplus	18	Turkey	24				

All Figures are height in meters.

Foundation Depths (m)

Height <i>H</i>	Distance from Center of tree or Hedge to face of foundations											
	1.00	2.00	3.00	4.00	5.00	6.00	7.00	8.00	9.00	10.0	11.0	12.0
8	3.25	3.00	2.75	2.50	2.26	2.30	1.75	1.50	1.26	1.00	1.00	1.00
10	3.30	3.1	2.90	2.70	2.50	2.50	2.10	1.90	1.70	1.60	1.30	1.10
12	3.33	3.17	3.00	2.83	2.67	2.64	2.33	2.17	2.00	1.83	1.67	1.50
14	3.36	3.21	3.07	2.93	2.79	2.75	2.50	2.36	2.21	2.07	1.93	1.79
16	3.38	3.25	3.13	3.00	2.88	2.83	2.63	2.50	2.38	2.25	2.13	2.00
18	3.39	3.28	3.17	3.06	2.94	2.90	2.72	2.61	2.50	2.39	2.26	2.17
20	3.40	3.30	3.20	3.10	3.00	2.95	2.80	2.70	2.60	2.50	2.40	2.30
22	3.41	3.32	3.32	3.14	3.05	3.00	2.86	2.77	2.68	2.69	2.50	2.41
24	3.42	3.33	3.25	3.17	3.08	3.04	2.92	2.83	2.75	2.67	2.58	2.50
26	3.42	3.35	3.27	3.19	3.12	3.04	2.96	2.88	2.81	2.73	2.65	2.58
28	3.43	3.36	3.29	3.21	3.14	3.07	3.00	2.93	2.86	2.79	2.70	2.64
30	3.43	3.37	3.30	3.23	3.17	3.10	3.03	2.97	2.90	2.83	2.77	2.70

Figure 4

Foundation Depths

High shrinkability soils: plasticity index greater than 40%

Source: National House Building Council, Chapter 4.2, (1992)

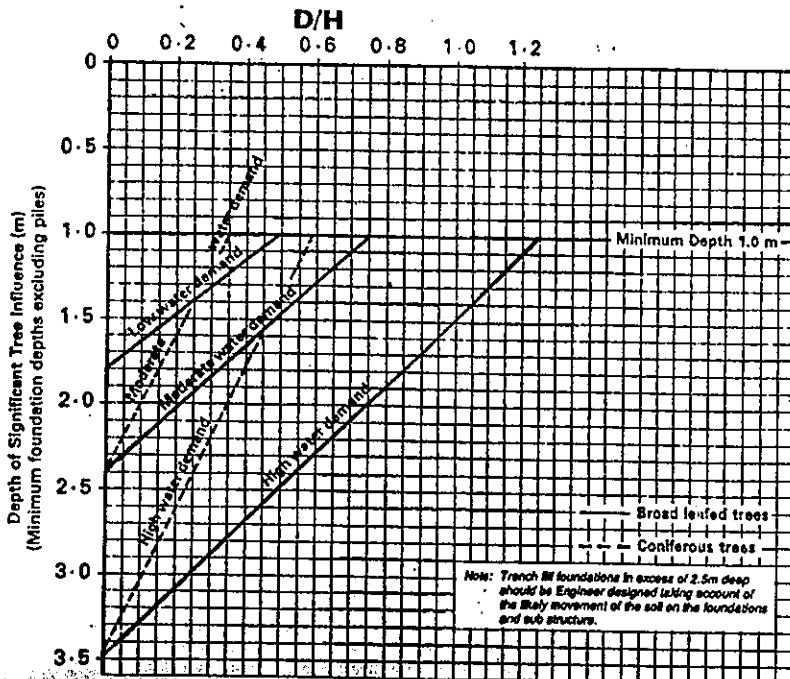

Table 5 Minimum Foundation Depth

<i>Shrinkage Potential</i>	<i>Minimum Depth (m)</i>
High	1.0
Medium	0.9
Low	0.75

5 *Appropriate Methods for Heave Control*

5.1 *Waffle Foundation*

It is possible to control the direction of expansion by allowing the soil to expand into cavities built into the foundations. A common practice is to build a waffle slabs so that the ribs hold the structure and the waffle voids tolerate the heave. This leads to reducing the foundation movements by allowing the expansion of the soil.

5.2 *Suitable Proprietary materials:*

There are two types of materials used to protect the foundations from heave. The first is a compressible material made from highly-compressible, low-density polystyrene which should be designed to minimize the effect of heave.

The second type of materials is the void-former which may be used as an alternative to the compressible materials. Clayboards have been used but there have been reported instances of degradation of the organic void former generating methane gas; *Atkins, (1994)*. The ground beams and the suspended slab should be designed to accommodate the pressure induced when the compressible materials are compressed as a result of soil heave. Table (6) and (7) show the minimum void dimensions to accommodate movements against foundations, ground movements and void dimensions for precast concrete slabs as required by the *National House Building Council, (1992)*.

Table 6 Minimum Void Dimensions Against Foundations & Ground Beams

soil heave potential	Underside of ground beams Void Dimensions mm	Against side of foundations Void dimensions mm
High	150	35
Medium	100	25
Low	50	0

Table 7 Minimum Void Dimensions under Ground floors

Soil heave potential	Precast Concrete Void dimensions mm
High	225
medium	175
Low	125

6 Foundations Constructional Details

All foundations should be designed to withstand the applied loads transmitted from the super-structure as well as any lateral pressures and forces.

6.1 Trench-Fill Foundations

Figure (5) and table (8) show the constructional details of trench-fill foundations. The compressible materials are placed on the inside face of foundations in order to reduce the effect of the clay heave active pressure of the dumpling enclosed within the foundations. This compressible materials is required only on the inside face of the external foundations as the internal foundations are protected from seasonal changes and normally the heave pressure on both sides is in equilibrium.

Figure 5
Constructional Details - Heave Precautions for Trench-Fill Foundations

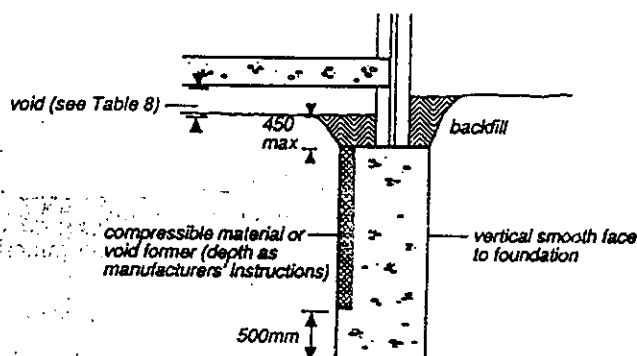

Table 8 Heave Precautions for Trench-Fill

Position of dwelling in relation to trees	Heave precautions required
Dwelling sited within zone of influence of trees remaining or to be removed, or over trees after removal.	Compressible materials or void former required against the inside face of all external wall foundations greater than 1.5m deep.
Dwelling sited within zone of influence new trees	Non - the soil has not been desiccated and therefore heave cannot take place.

6.2 Pile and Ground Beam Foundations

All piles should be designed to withstand all horizontal and vertical loads resulted from the super-structures as well as the forces arising from the skin friction and soil movements due to swelling or shrinkage. Compressible materials or void formers are required beneath the ground beams so that the upward pressure, acting on the underside of the beams, from swelling is reduced. Rigid slip liners may be used to reduce the effect of the tensile forces transmitted to the pile when the soil is rehydrated. Heave precautions for pile and ground beams are shown in figure (6) and table (9).

Figure 6
Constructional Details - Heave Precautions for Pile and Ground Beam

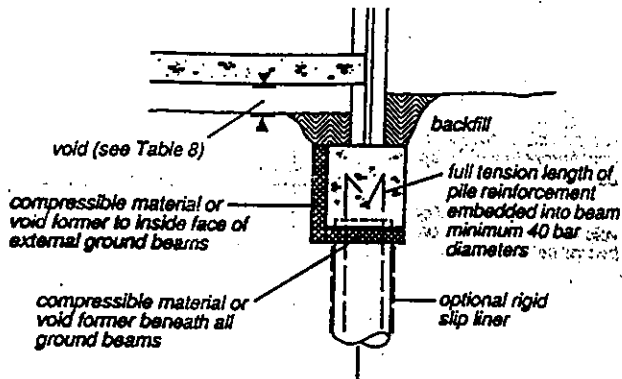

Table 9 Heave precautions for pile and ground beam foundations

Position of Dwelling in relation to trees	Heave precautions required
Dwelling sited within zone of influence of trees remaining or to be removed, or over trees after removal	Piles to be designed with an appropriate factor of safety to resist tensile heave forces. Piles to be reinforced for their full length. A void, void former or compressible materials should be provided below all ground beams. A compressible material or void former should be provided against the insides face of external ground beams.
Dwelling sited within zone of influence of new trees	Non - The soil has not been desiccated and heave can not take place.

6.3 Pier and Ground Beam Foundations

a void former or compressible materials should be used to protect all side of the pier from heave movements when the depth is in excess of 1.5m. It should be noticed that the compressible materials is not taken to the bottom of the pier so as not to avoid disturbing the foundation bearing strata. Heave precautions for pier and ground beam foundations are shown in figure (7) and table (10).

Figure 7
Constructional Details, Heave Precautions, Pier and Ground Beam Foundations

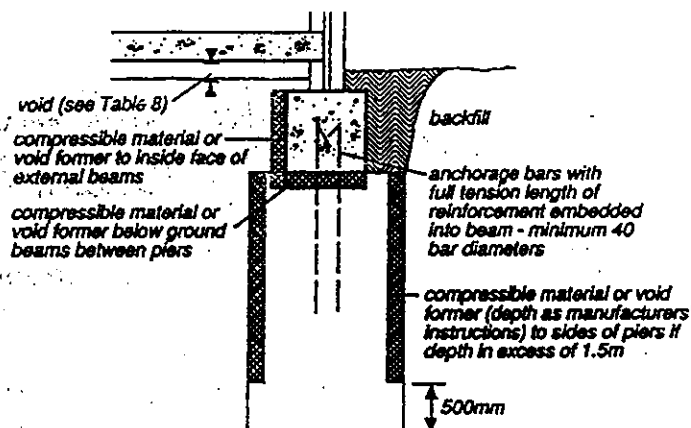

Table 10
Heave Precautions for Pier and Ground Beam Foundations

Position of dwelling in relation to trees	Heave precautions required
Dwelling sited within zone of influence of trees remaining or to be removed, or over trees after removal.	Compressible material or void former should be provided against faces of all pier foundations greater than 1.5m deep. Compressible materials should be provided under all ground beams and against the inside face of all external ground beams.
Dwelling sited within zone of influence of new trees	Non - the soil has not been desiccated and therefore heave cannot take place.

7 Conclusion

The practical experience with expansive soils can classify them by the degree of volume change by using the index properties. This is because the change in the soil suction can not be practically measured. Therefore, the main purpose of the foundation techniques explained in this paper is limit the structural distortion resulting from soil expansions and swelling and consequently limiting the defects in the structural serviceability limit state "SLS".

The only caution the authors would like to put forward for discussion is the blind use of table (5) of the National House Building Council. This table did not take the unplanned seeding and planting of trees and gives a foundation depth of 1m which may not be sufficient if trees grow without planning and consequently subsidence may take place. However, the authors believe that the NHBC tables are user-friendly because these tables show the relationship between the Plasticity Index with Shrinkage Potential and the minimum foundation depth. The tables also give the required distance from center of tree to the face of foundation as a function of the foundation depth. The minimum distance between trees and structures is dependent on the type of trees because the Swelling/Shrinkage potential is affected by the type of these trees. However the National House Building Council Standards provide a good guidance to practical engineers in order to design and construct safe foundations on expansive clay soils.

References

Atkins, R, (1994), Building near trees, The Structural Engineers/volume 72/No. 16/16 August, England.

Building Research Establishment, (1981), Assessment of Damage in Low Rise Building, BRE Digest 251, HMSO, London.

Chen, F, (1987), Current Status on Legal Aspects of Expansive Soils, 6th International Conference on Expansive Soils, New Delhi, India..

Das, B, (1985), Advanced Soil Mechanics, McGraw-Hill International Editions.

Holtz and Gibbs, (1956), Engineering Properties of Expansive Soils, Trans ASCE, p641.

Jones, E, (1979), The Expansive Soil Problem. Underground Space 3 (5), 221-226.

Nayak and Christensen, (1971), Swelling characteristics of Compacted Expansive Soils, Clay and Clay Min., vol. 19, pp. 251-261.

NHBC Standards, (1985), Practice Note (3), U.K.

NHBC Standards, (1992), Chapter 4.2, Building near trees, U.K.

Reece, R., (1980) Insurance & The Cost of Mistakes, Trees in relation to construction,. British Standard Institution, London, pp28-36.

Root damage by trees, (1974) - Siting of Dwelling and Special Precautions. NHBC Practice note 3, U.K.

Redrawn, (1959), Structures and Strength Characteristics of Compacted clays, J. Soil Mechanics. Foundations Division, ASCE, vol. 85, no. SM5.

Ransom, W, (1987), Building Failures Second Edition, University Press Cambridge UK.

Seed et al, (1962), Predicting of Swelling Potential for Compacted Clays, J of Soil Mechanics Foundations, Engineering Division, ASCE, vol. 88, no. SM, pp53-87.

Taylor, R, (1985), Mineralogical controls on volume change, Conference Issue, U.K.